

1859-12450A-00-xx_R00

ITEM	QTY.	DESCRIPTION	PART NUMBER	MATERIAL
1	1	VST-80 I.G. @ 1.9 S.G.	1039-02450T-00-xx	PE
2	1	6" SCREW CAP	9707-016000-80-10	10 HDPE
3	1	6" SCREW CAP GASKET	9707-056000-00-65	65 EPDM
4	1	1.0" [25 MM] FNPT BOSS	9701-011000-00-00	00 MDPE

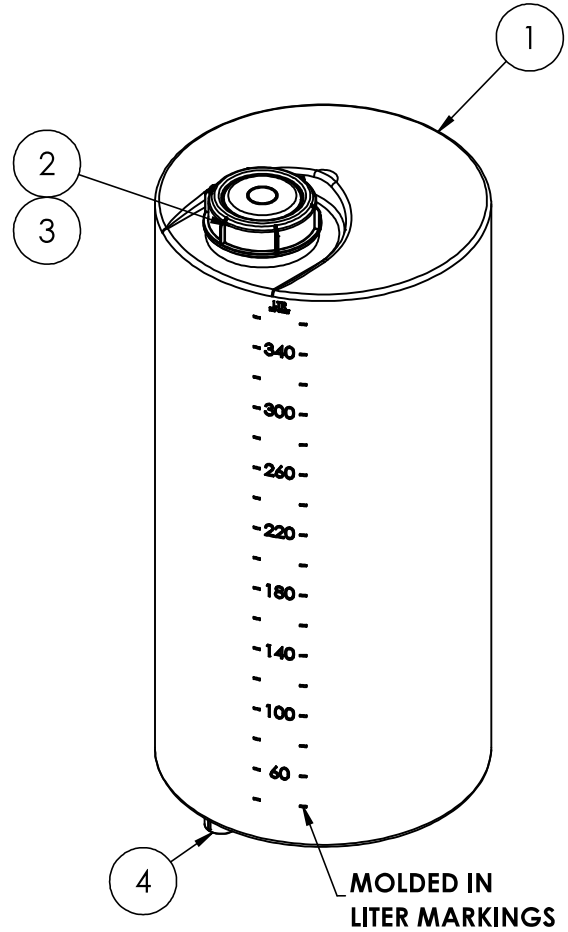
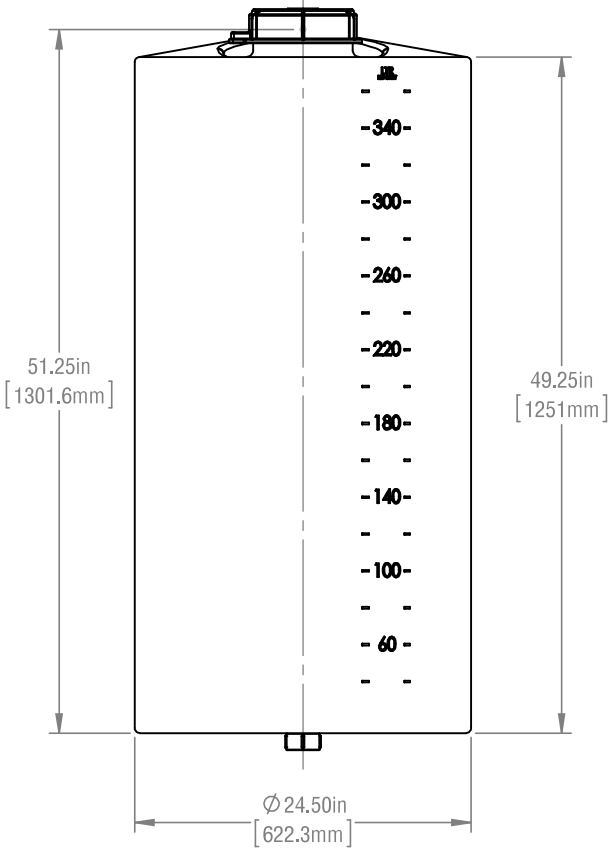
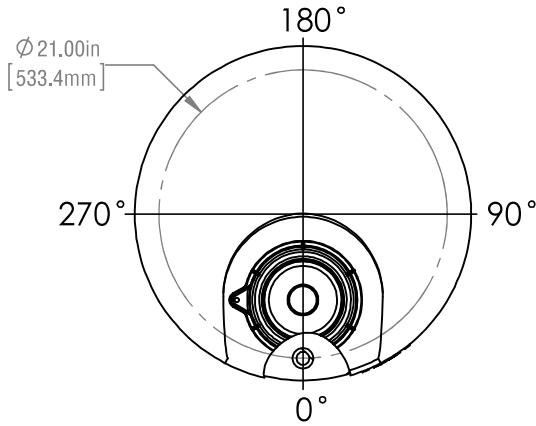

- NOTES:
 1) REFER TO PLAN VIEW FOR FITTING ORIENTATION
 2) ALL TRIMMED EDGES ARE ROUNDED OFF
 3) ALL DIMENSIONS ARE APPROXIMATE
 4) CAPACITY 80 IG (95 USG/360 L)

FAILURE TO PROVIDE ADEQUATE PROVISIONS FOR TANK EXPANSION/CONTRACTION AT FITTINGS WILL VOID ALL WARRANTIES.

****TANK AVAILABLE IN 00 MDPE OR 10 HDPE****

REVISIONS		
REV.	DESCRIPTION	DATE
00	KP - CREATED LAYOUT	2016-03-17

FINAL APPROVED DRAWING CUSTOMER:..... DATE:.....